

The Foundation (federal) for Assistance to Small Innovative Enterprises (FASIE)



•Chartered by	- The government of Russia, 03.02.1994
•Financed through	- 1,5% of federal budget for R&D (24,0 €mln for 2005)
•Form of assistance	- The state contract for R&D
•Policy and control by	- The observing council
•Operation by	- Directorate
•Expertise	- Independent experts
•Decision by	- Jury
•Regional policy through	- Regional delegates
•Information resource	- www.fasie.ru

SOME RESULTS (10 years)

Applications	- more than 10000
Contracts	- more than 3000
Average turnover	- US\$ 500 thousands
Average growth	- 20% per year
Number of commercialized patents	- more than 1000
Number of issued patents	- more than 1000
Companies with turnover	
more than US\$ 1mln	- about 100
more than US\$ 5 mln	- more 10
more than US\$ 30 mln	- 3

START

Targets

- Commercialization of basic research
- Share of risk with investors
- Start-up development

PhI to PhII criteria

- To get investor

Situation

- 2004**
- 2762 applications
 - 538 contracts for 13 M\$
 - 429 new companies
 - 10 companies got investors (from 30 after Phase1)
- 2005**
- budget - 12 M\$
 - 1657 applications
 - 419 - projects accepted

Organization

- Expertise on regional level
- face – to - face review

Priorities START 05

From **1649** applications:

- Information technologies - **271**
- Medicine and pharmacology - **211**
- Chemistry and new materials - **330**
- Instruments, electronic devices and machines - **643**
- Biotechnology and agriculture - **194**

ELEMENTS OF EXPERTISE

- LEVEL OF SCIENCE
- NOVELTY OF IDEA
- PROTECTION OF IPR
- COMMERCIALIZATION'S FEASIBILITY
- ANALYSIS OF RISKS
- FINANCIAL AND ECONOMICAL ISSUES
- TEAM'S QUALITY

Regional distribution 2004/2005

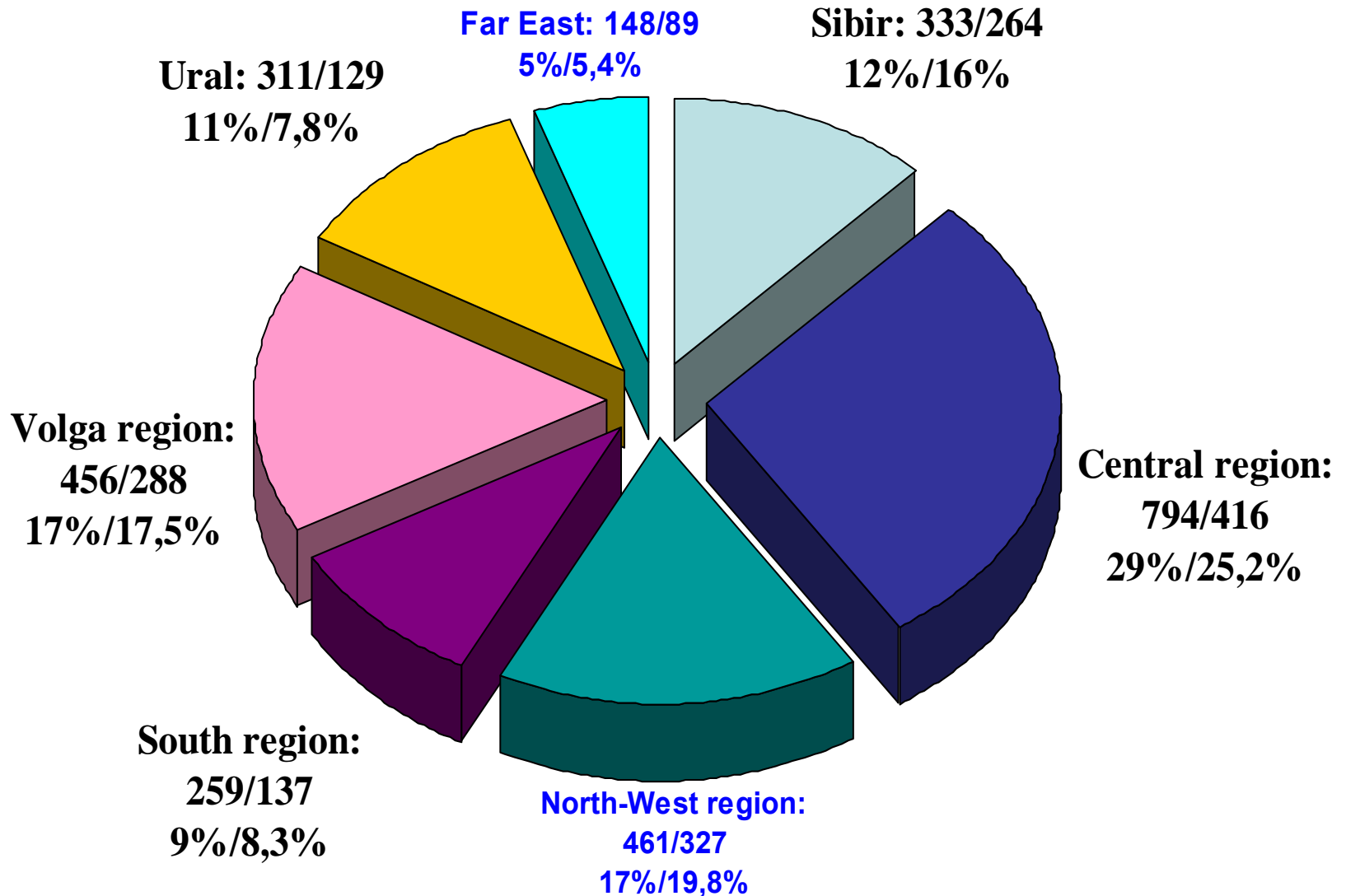

Types of organizations

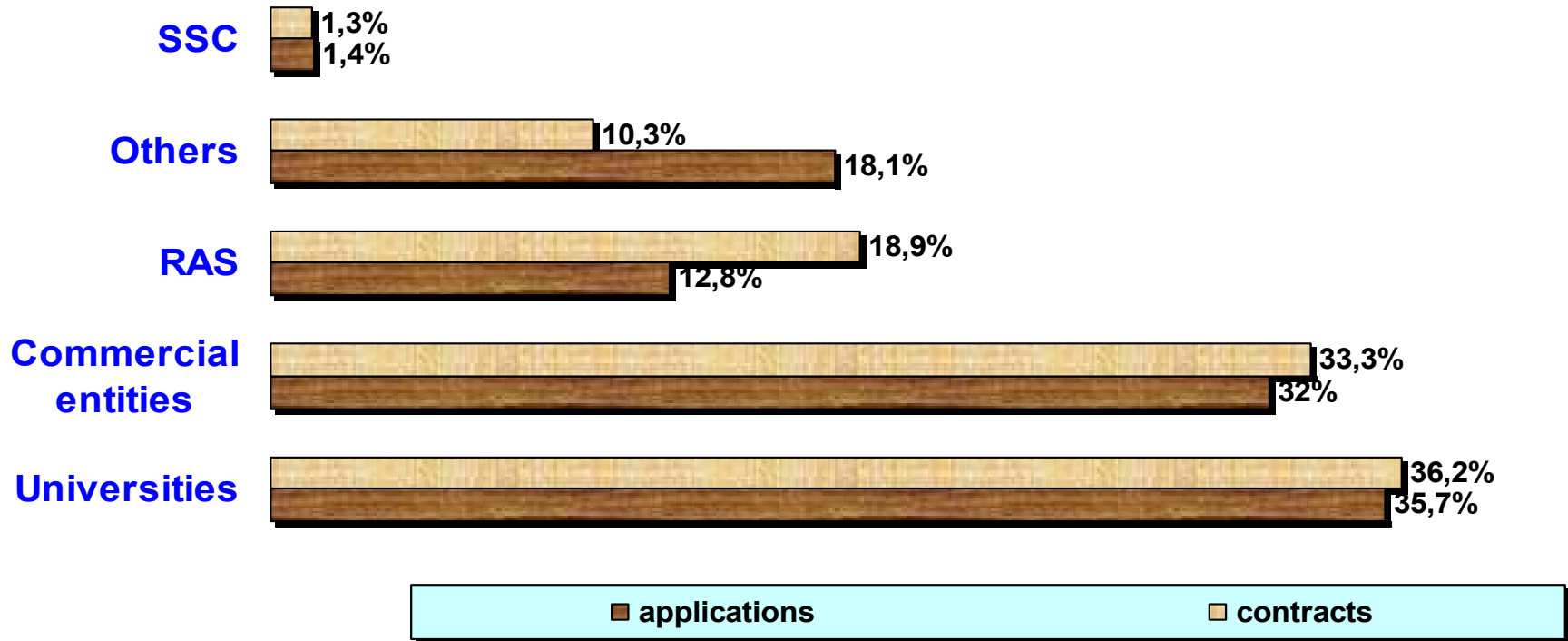

Problems of NIS

Programmes of Foundation

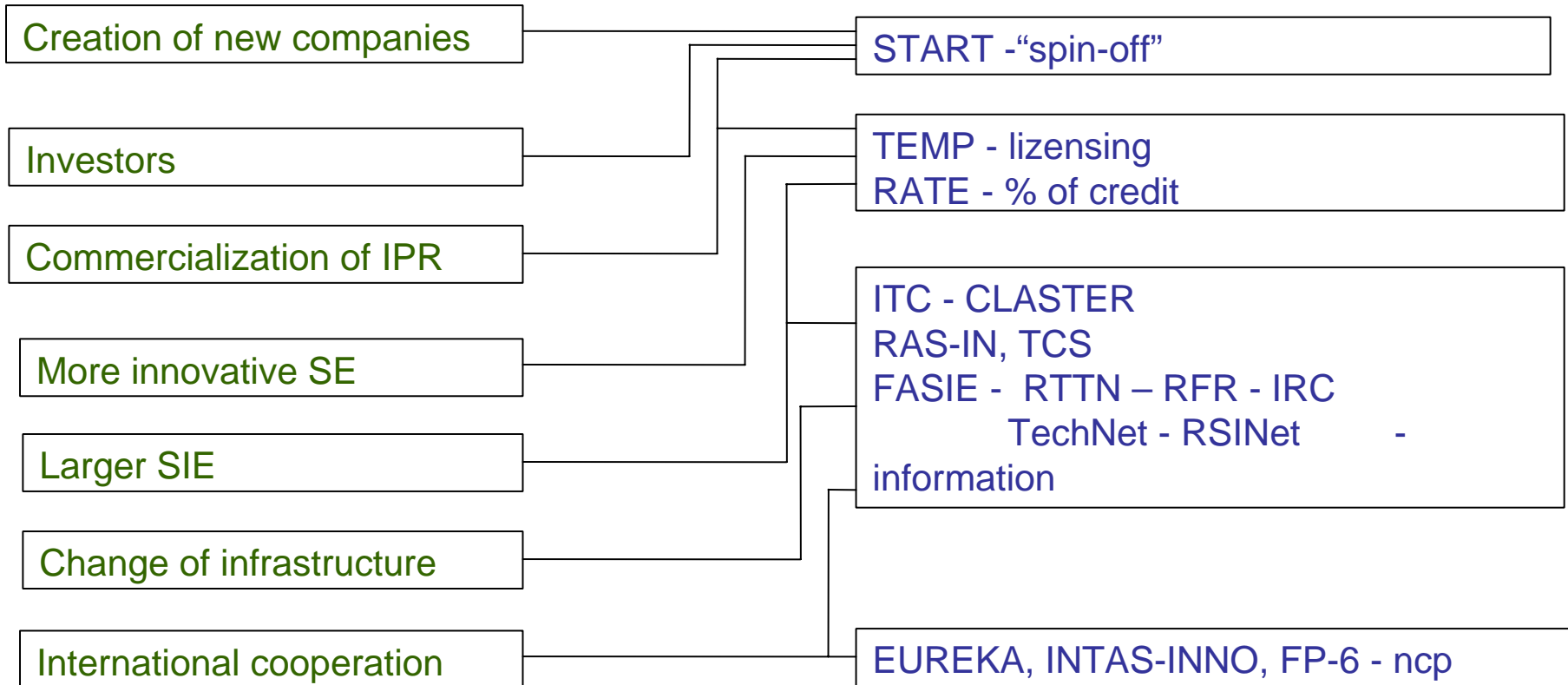

TEMP (TEchnologies to Small Enterprises)

IPR owner

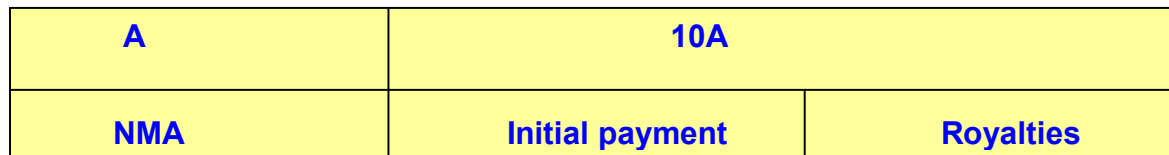

SE

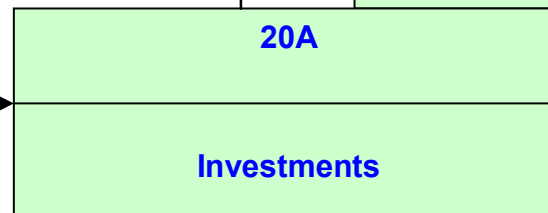
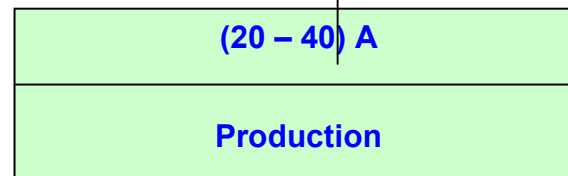

FASIE

