

Prof. Sergey Polyakov
Deputy Director-General
FASIE

polyakov@fasie.net



The Foundation (federal) for Assistance to Small Innovative Enterprises (FASIE)

•Chartered by	- The government of Russia, 03.02.1994
•Financed through	- 1,5% of federal budget for R&D (24,0 €mln for 2005)
•Form of assistance	- The state contract for R&D
•Policy and control by	- The observing council
•Operation by	- Directorate
•Expertise	- Independent experts
•Decision by	- Jury
•Regional policy through	- Regional delegates

SOME RESULTS (since 1994)

Applications	- more than 10000
Contracts	- more than 3000
Average turnover	- US\$ 500 thousands
Average growth	- 20% per year
Number of commercialized patents	- more than 1000
Number of issued patents	- more than 1000
Companies with turnover	
more than US\$ 1mln	- about 100
more than US\$ 5 mln	- dozens
more than US\$ 30 mln	- 3

START

Targets

- Commercialization of basic research
- Share of risk with investors
- Start-up development

Organization

- Expertise on regional level
- face – to - face review

Situation

Results of 2004 round – from 2762 applications 538 contracts for 13 M\$, 429 new companies formed, 77 companies got investors in 2005-2006 (after Phase1)

- 2005
- budget - 12 M\$
 - 1657 applications
 - 419 - projects accepted

Priorities START 05

From **1649** applications:

- Information technologies - **271**
- Medicine and pharmacology - **211**
- Chemistry and new materials - **330**
- Instruments, electronic devices and machines - **643**
- Biotechnology and agriculture - **194**

PRIORITIES

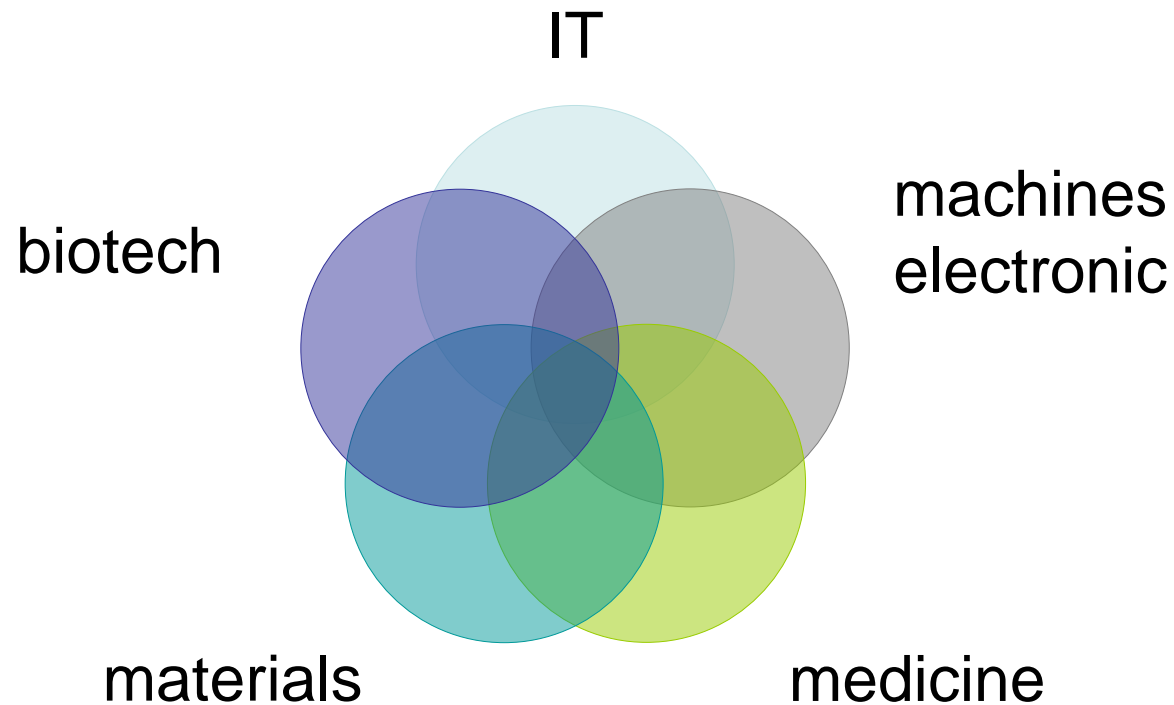

ELEMENTS OF EXPERTISE

- LEVEL OF SCIENCE
- NOVELTY OF IDEA
- PROTECTION OF IPR
- COMMERCIALIZATION'S FEASIBILITY
- ANALYSIS OF RISKS
- FINANCIAL AND ECONOMICAL ISSUES
- TEAM'S QUALITY

COMPOSITION OF REVIEW TEAM

(for each priority)

REGIONAL, 9 MEMBERS

- 1 - chairman
- 2 - from basic science
- 2 - from applied science
- 2 - from high-tech business
- 1 - from investors
- 1 – from FOND's tender committee

INTERREGIONAL, 8 MEMBERS

- 1 – chairman, FOND'S Director
- 7 – chairmen of regional reviews

Regional distribution 2004/2005

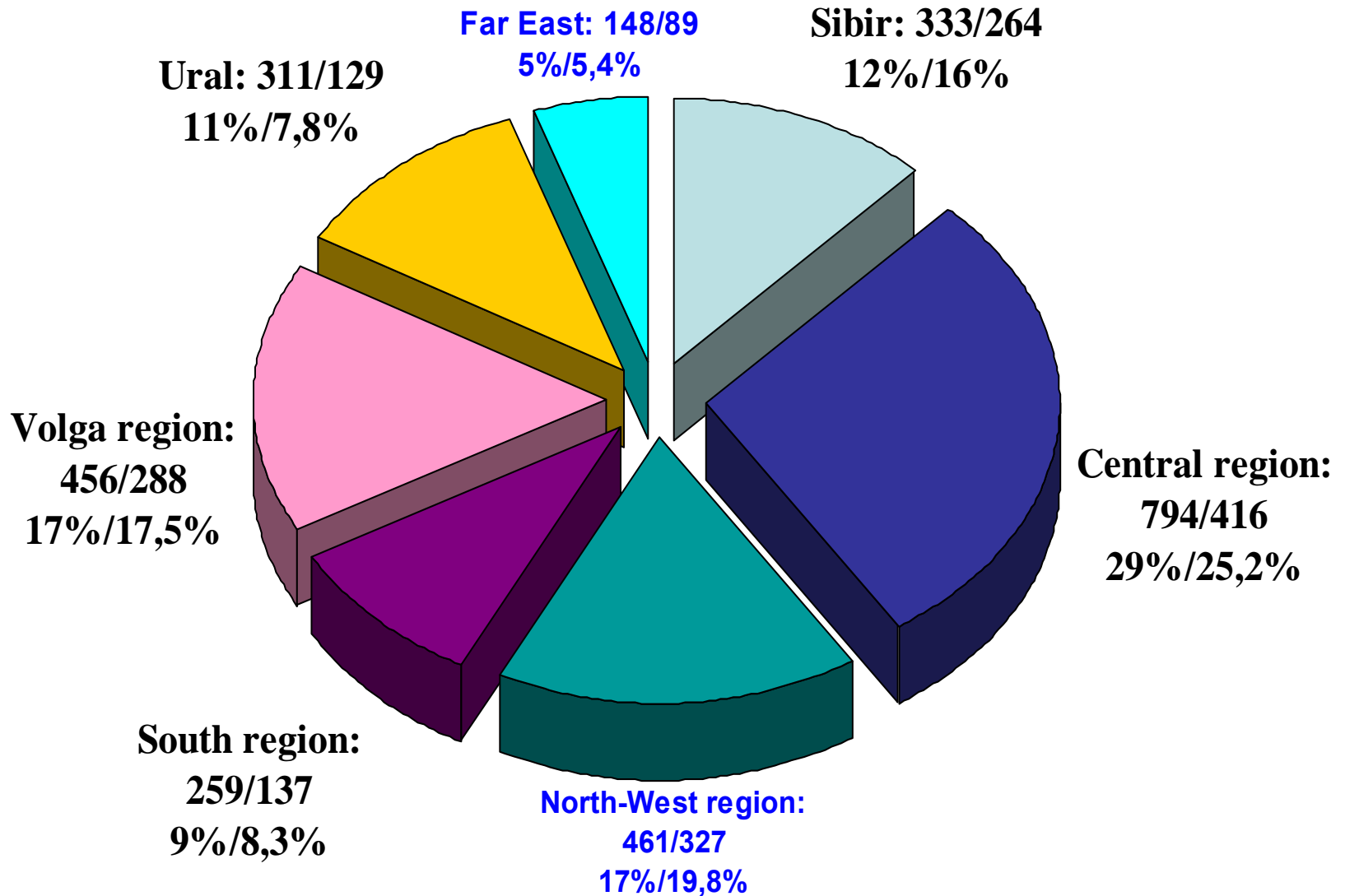

Problems of NIS

Programmes of Foundation

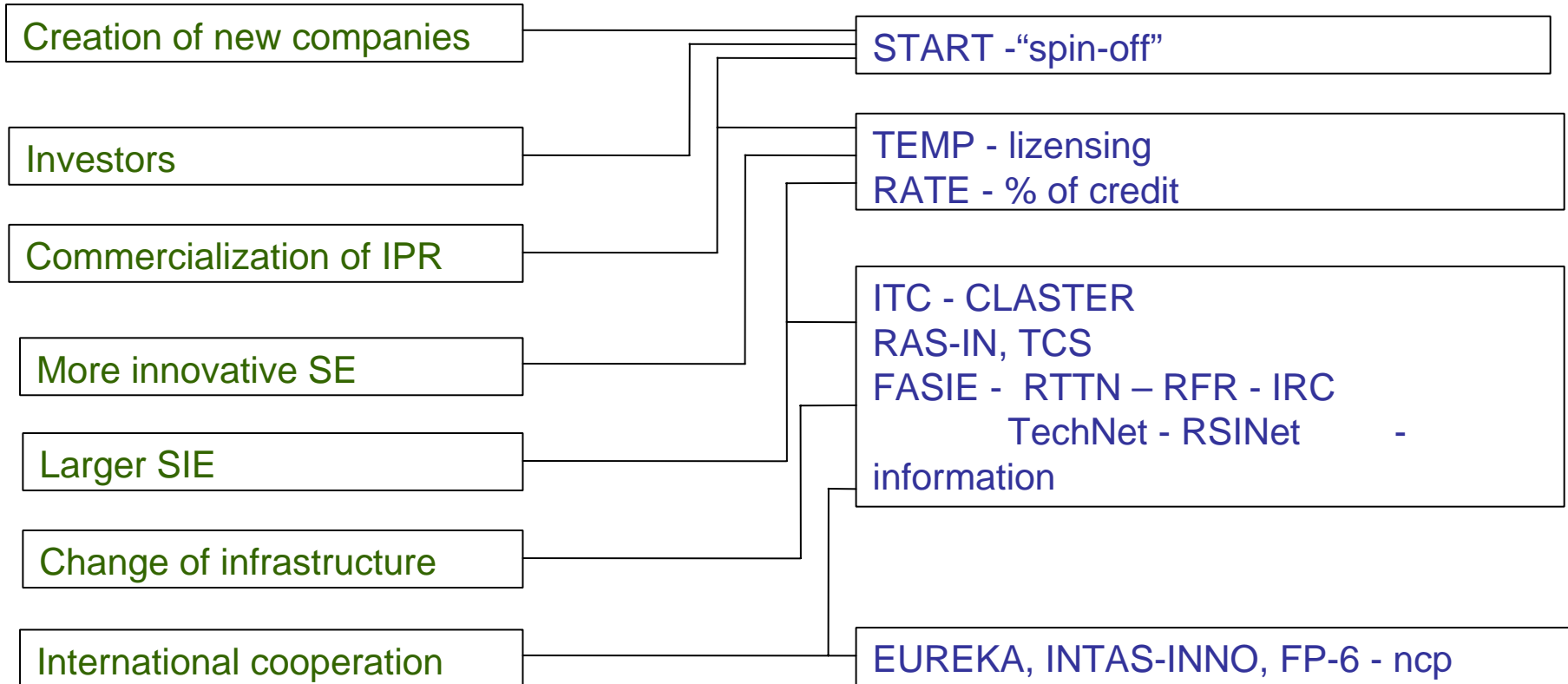

Volume of sales – example of 10 high-tech companies supported by FASIE (in thousands US\$)

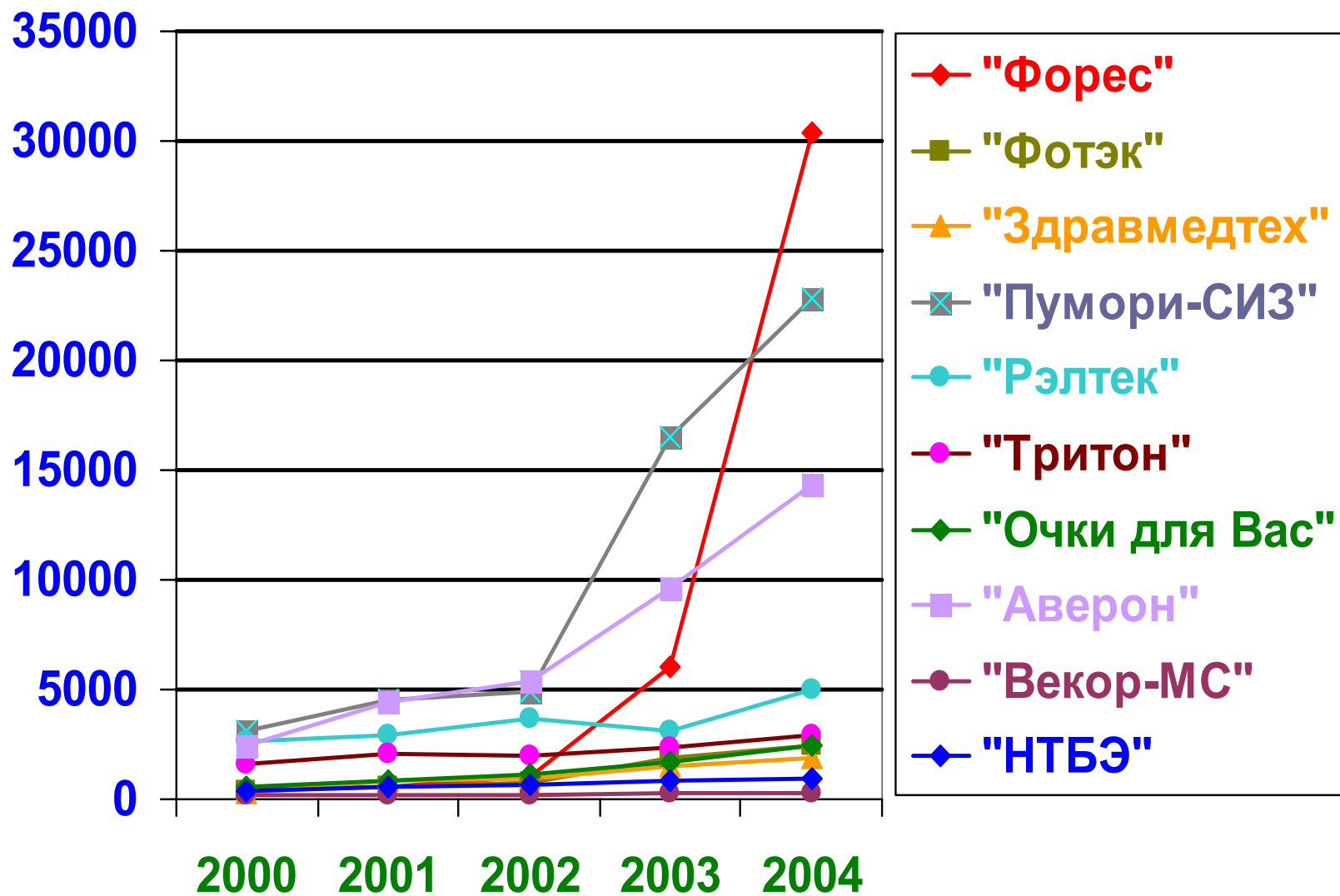

IP protection (patents, trademarks, etc.) - example of 10 companies supported by FASIE

